

PRODUCT SPECIFICATIONS

# Metal X

The Metal X is a revolutionary 3D printer that prints metal powder bound in a plastic matrix to eliminate safety risks associated with traditional metal 3D printing methods while enabling new features like close-cell infill for reduced part weight and cost. It's up to 10x less expensive than alternative metal additive manufacturing technologies — and up to 100x less than traditional fabrication technologies like machining or casting. Affordable, reliable, and easy to use, the Metal X print system gives you everything you need to go from design to fully functional metal parts faster than ever before.

<b>Printer Properties</b>	<b>Process</b>	Atomic Diffusion Additive Manufacturing (ADAM)
	<b>Build Volume</b>	300 x 220 x 180 mm (11.8 x 8.7 x 7.1 in)
	<b>Machine Size</b>	575 x 467 x 1,120 mm (22.7 x 18.4 x 44.1 in), 75 kg (160 lbs)
	<b>Print Chamber</b>	Heated
	<b>Print Bed</b>	Heated, vacuum-sealed print sheet, auto bed leveling
	<b>Print System</b>	Two nozzles — Metal material and release material
	<b>Power Requirements</b>	100–120 / 200–240 VAC (12A / 6A), IEC 60320 type C20
<b>Materials</b>	<b>Metal Material</b>	Stainless steel (17-4 PH, 316L*), Tool steel (H13, A2, D2), Inconel 625, Copper, Titanium-6Al-4V*
	<b>Release Material</b>	Ceramic (consumed at 1:10 ratio to metal spools, on average)
	<b>Media (Spools)</b>	Filament fed, bound powder
<b>Part Properties</b>	<b>Max Part Size</b>	250 x 183 x 150 mm (9.8 x 7.2 x 5.9 in), 10kg
	<b>Supports</b>	Metal material with ceramic release layer
	<b>Layer Height</b>	50µm and 125µm post-sinter
<b>Software</b>	<b>Supplied Software</b>	Eiger Cloud (Other options available at cost)
	<b>Security</b>	Two-factor authentication, org admin access, single sign-on

**FRONT VIEW**

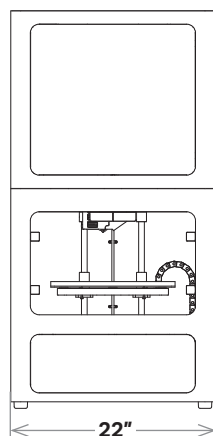

**SIDE VIEW**

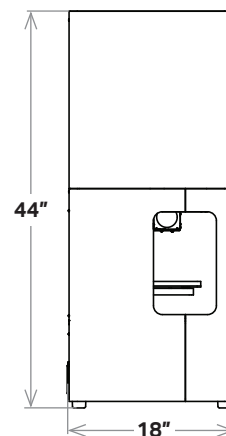

\* Materials currently under development. **Note:** All specifications are approximate and subject to change without notice.

PRODUCT SPECIFICATIONS

# Wash-1

The first step in transforming a printed “green” part into fully dense metal is debinding. The Wash-1 immerses the green part in a specialized fluid which dissolves the primary binding material, leaving the part semi-porous so the remaining binder can easily burn off during sintering. This debinding step purifies the final metal part and helps keep your sintering furnace clean.

<b>Debinder Properties</b>	<b>Materials Supported</b>	All metals
	<b>Fluid (Solvent)</b>	Opteon SF79, Opteon SF80, or Tergo Metal Cleaning Fluid
	<b>Controller</b>	Integrated control system
	<b>Workholding</b>	Stainless steel basket
	<b>Washing Size</b>	356 x 254 x 203 mm (14 x 10 x 8 in)
	<b>Washing Volume</b>	18,356 cm <sup>3</sup> (1,120 in <sup>3</sup> )
<b>Safety &amp; Installation</b>	<b>Environmental Req.</b>	External exhaust
	<b>Safety Control</b>	Low fluid shutoff control High vapor pressure shutoff control
	<b>Regulatory</b>	Refer to MSDS
	<b>Emissions</b>	Low emission design to conserve solvent
	<b>Power</b>	110-120 VAC single phase, 11A / 1,320W peak draw
<b>Physical Dimensions</b>	<b>External Dimensions</b>	609 x 685 x 1,067 mm (24 x 27 x 42 in)
	<b>Weight</b>	136 kg (300 lbs)

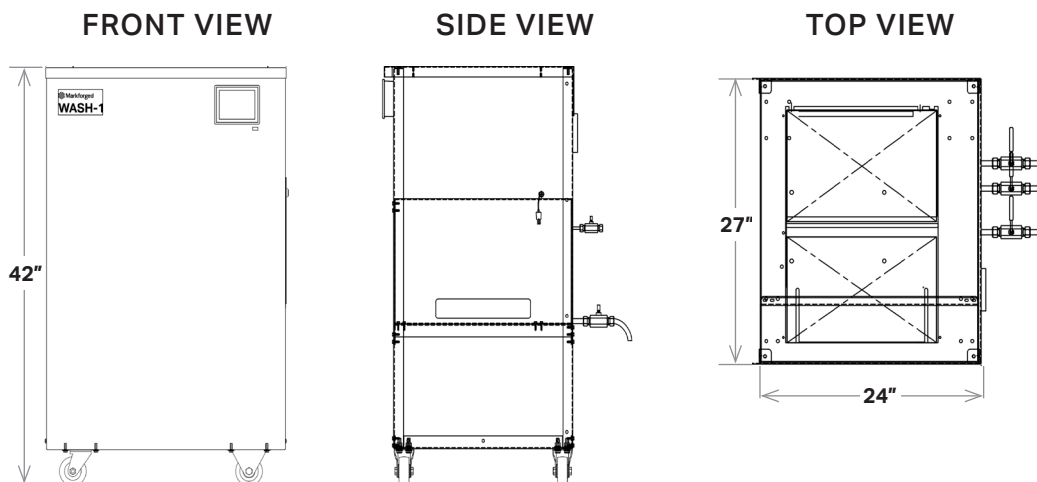

**Note:** All specifications are approximate and subject to change without notice.

PRODUCT SPECIFICATIONS

# Sinter-1

The Markforged Sinter-1 is a high-performing, high-value furnace that is ideal for small batch production. Built on 30 years of Metal Injection Molding (MIM) technology, it's affordable and reliable. Featuring 4,760 cm<sup>3</sup> of active hot zone, the Sinter-1 effortlessly converts washed parts into their high-quality dense final metallic form in as few as 26 hours.

<b>Furnace Properties</b>	<b>Materials Supported</b>	Chemically debound Metal X-printed parts
	<b>Heating Element</b>	Kanthal
	<b>Controller</b>	Pre-programmed automatic cycling
	<b>Sinter Run Time</b>	26 hours*
	<b>Peak Internal Temp.</b>	1,300° C / 2,372° F
	<b>Sintering Capacity</b>	Rectangle w/radius top — 141 mm ID x 305 mm L (5.55 in ID x 12 in L)
	<b>Sintering Workload</b>	3,020 cm <sup>3</sup> (184 in <sup>3</sup> )
	<b>Sinter Surface Area</b>	348 cm <sup>2</sup> (53.9 in <sup>2</sup> ) for single ceramic setter plate
	<b>Setter Plate Dimensions</b>	11.4cm W x 30.4cm D, (4.5in W x 12.0in D)
	<b>Gas Types</b>	Argon, argon / hydrogen mix
	<b>Retort</b>	High purity refractory retort (carbon-free)
	<b>Safety &amp; Installation</b>	<b>Environmental Req.</b>
<b>Power</b>		200–240 V single phase 30A, recommend wiring 50A
<b>Physical Dimensions</b>	<b>External Dimensions</b>	1,270 x 510 x 720 mm (50 x 20 x 28 in)
	<b>Weight</b>	136 kg (300 lbs)

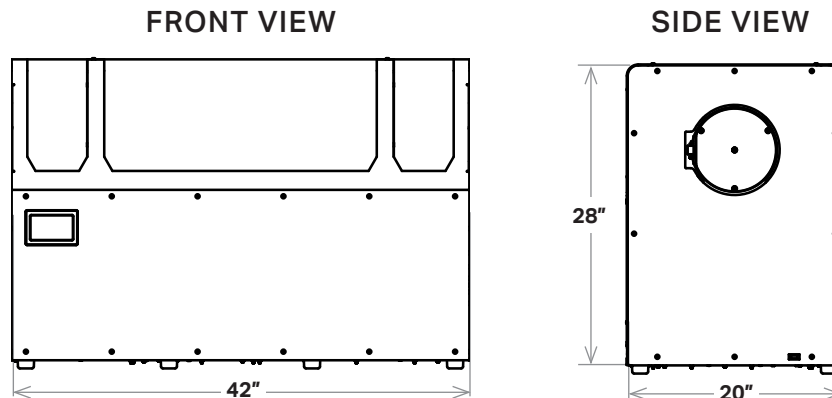

\* May vary by material. **Note:** All specifications are approximate and subject to change without notice.

PRODUCT SPECIFICATIONS

# Sinter-2

With an expansive active hot zone (19,644 cm<sup>3</sup> / 1,199 in<sup>3</sup>), the Sinter-2 is the perfect solution for mid-volume batch production and for larger parts. Create high-purity metal parts by using sintering technology built with a carbon-free retort. This workhorse furnace is enabled with rapid cooling technology and can process the full range of commercial-grade metals from their washed state into dense metal parts in as few as 30 hours.

<b>Furnace Properties</b>	<b>Materials Supported</b>	Chemically debound Metal X-printed parts
	<b>Heating Element</b>	Kanthal
	<b>Controller</b>	Pre-programmed automatic cycling
	<b>Sinter Run Time</b>	30 hours*
	<b>Peak Internal Temp.</b>	1,300° C / 2,372° F
	<b>Sintering Capacity</b>	Rectangle w/radius top — 248 mm ID x 406 mm L (9.8 in ID x 16 in L)
	<b>Sintering Workload</b>	12,135 cm <sup>3</sup> (741 in <sup>3</sup> )
	<b>Sintering Surface Area</b>	1,644 cm <sup>2</sup> (254.8 in <sup>2</sup> ) for stackable ceramic setter plate
	<b>Setter Plate Dimensions</b>	Top plate: 24.0cm W x 41.0cm D, (9.4in W x 16.1in D) Bottom plate: 17.0cm W x 41.0cm D, (6.7in W x 16.1in D)
	<b>Gas Types</b>	Argon, argon / hydrogen mix
	<b>Retort</b>	High purity refractory retort (carbon-free)
	<b>Safety &amp; Installation</b>	<b>Environmental Req.</b>
<b>Power</b>		200–240 V, 3 phase (3 wire), 30 A 346–416 V, 3 phase (4 wire), 30 A
<b>Physical Dimensions</b>	<b>External Dimensions</b>	1,370 x 810 x 1,520 mm (54 x 32 x 60 in)
	<b>Weight</b>	350 kg (772 lbs)

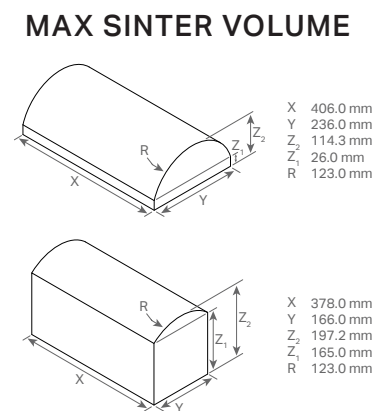
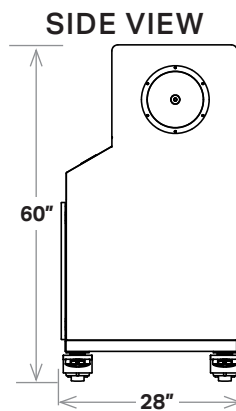
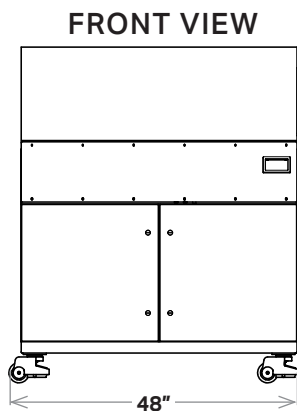

\* May vary by material, operating environment, run mass, electrical frequency, etc. **Note:** All specifications are approximate and subject to change without notice.